

# FILTRO DEPOLVERATORE



## FCSI 36/18



### Caratteristiche Filtro Depolveratore FCSI36/18

- Superficie filtrante 18 m<sup>2</sup>;
- Pulizia delle calze a contro lavaggio pneumatico;
- Calze in agugliato poliestere 500 g/m<sup>2</sup> , Ø 120x1300 mm con attacco SNAP;
- Velocità max consigliata di attraversamento calze 1,5 m/1';
- Consumo aria per pulizia calze 180 l/1' circa;
- Pressione massima di esercizio 5 ate;
- Quadro per gestione pulizia calze con o senza pressostato;
- Tensione alimentazione quadro elettrico 24/110/220V AC;
- Corpo filtro in Aisi 304 2B con portello di ispezione;
- Cappello in Fe360B zincato;
- Predisposizione per camino o aspiratore

FILTRI DEPOLVERATORI



CON O SENZA  
PRESSOSTATO  
DIFFERENZIALE

INSTALLAZIONE SU  
SILO O A TERRA SU  
TRAMOGGIA

SUPERFICIE  
FILTRANTE 18 M<sup>2</sup>

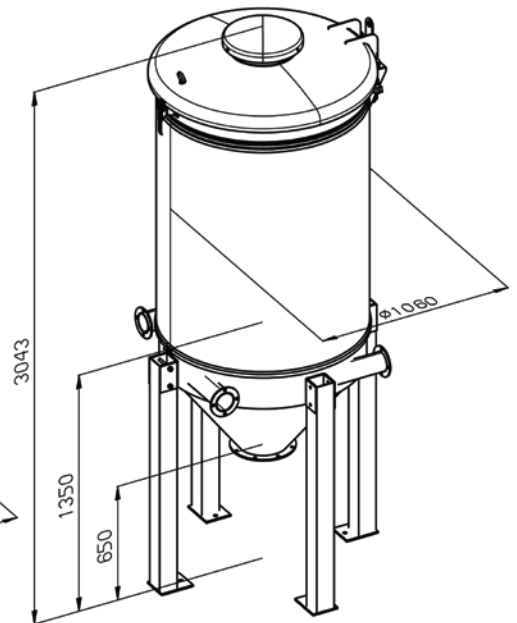
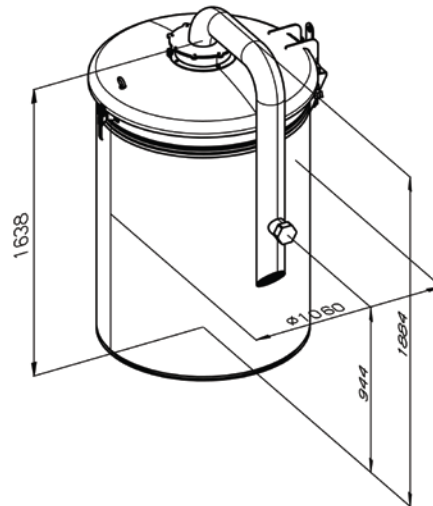
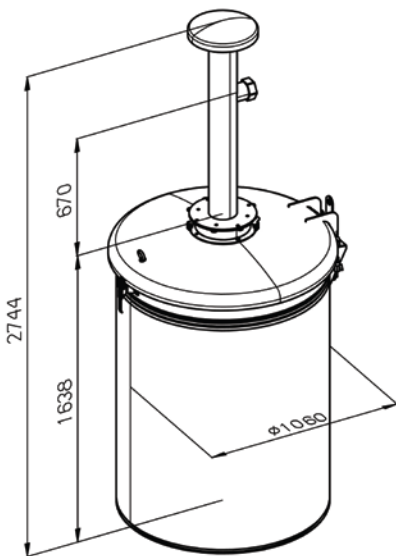
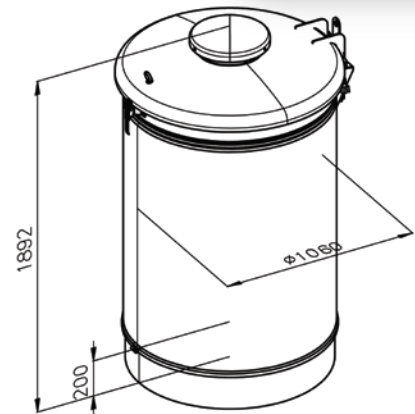
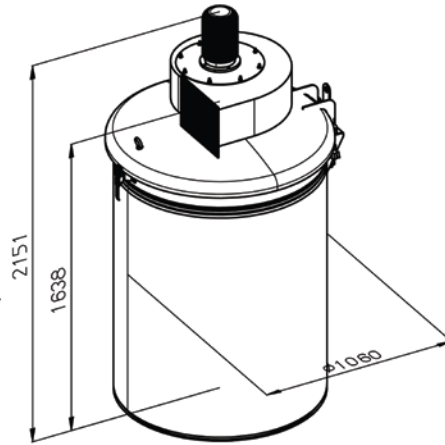
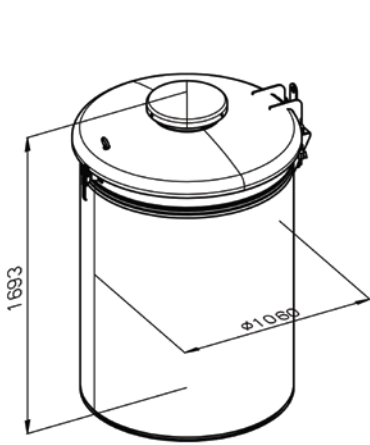

Modello Filtro	Codice magazzino	Superficie filtrante	Diametro filtro mm	H= Filtro mm	Numero calze	Numero EV	Dimensioni imballo mm	Peso lordo kg
FCSI36/18+ quadro	68.100.0363	18 m <sup>2</sup>	1060	1693	36	4	1100x1100x1800	150
FCSI36/18+ quadro+pressostato	68.100.0362	18 m <sup>2</sup>	1060	1693	36	4	1100x1100x1800	150

**CAMS INDUSTRIALE S.P.A.**  
Strada S. Michele, 37 Cailungo B5 BORGO MAGGIORE  
REPUBBLICA DI SAN MARINO  
Tel. +378.0549.988111 Fax +378.0549.903793  
[www.camsgroup.com](http://www.camsgroup.com) info@camsgroup.com

