

# FILTRO DEPOLVERATORE



## FCSI 3/1



### Caratteristiche Filtro Depolveratore FCSI3/1

- Superficie filtrante 1 m<sup>2</sup>;
- Pulizia delle calze a contro lavaggio pneumatico;
- Calze in agugliato poliestere 500 g/m<sup>2</sup> , Ø 120x830 mm con attacco SNAP;
- Velocità max consigliata di attraversamento calze 1,5 m/1';
- Tensione alimentazione quadro elettrico 24/48/110/V AC;
- n.1 elettrovalvola da ¾'
- Corpo filtro in Aisi 304 2B;
- Predisposizione per camino o aspiratore.

FILTRI DEPOLVERATORI



SU RICHIESTA,  
PULIZIA CALZE  
A VIBRAZIONE

INSTALLAZIONE SU  
BILANCE O PICCOLI  
MESCOLATORI

SUPERFICIE  
FILTRANTE 1 M<sup>2</sup>



FCSI 3/1  
Cod.68.100.0031

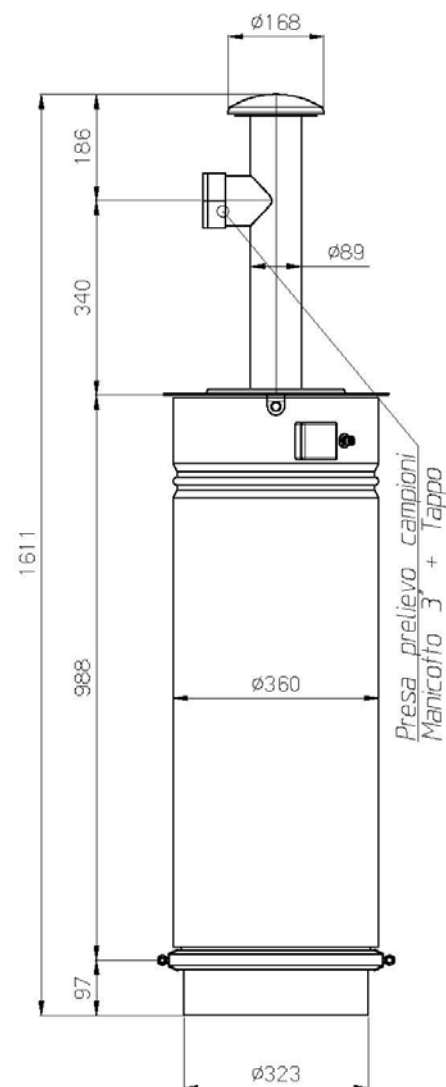
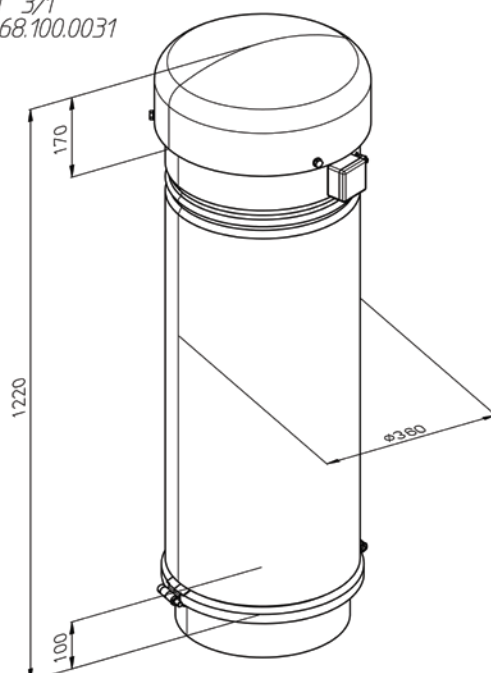
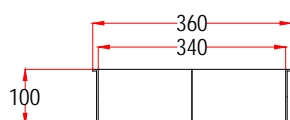

Modello Filtro	Codice magazzino	Superficie filtrante	Diametro filtro mm	H= Filtro mm	Numero calze	Numero EV	Dimensioni imballo mm	Peso lordo kg
FCSI3/1 24V AC	68.100.0031	1 m <sup>2</sup>	360	1000	3	1	420x420x1170	30
FCSI3/1 24V CC	68.100.0032	1 m <sup>2</sup>	360	1000	3	1	420x420x1170	30
FCSI3/1 110V AC	68.100.0033	1 m <sup>2</sup>	360	1000	3	1	420x420x1170	30
FCSI3/1 48V AC	68.100.0035	1 m <sup>2</sup>	360	1000	3	1	420x420x1170	30

**CAMS INDUSTRIALE S.P.A.**  
Strada S. Michele, 37 Cailungo B5 BORGO MAGGIORE  
REPUBBLICA DI SAN MARINO  
Tel. +378.0549.988111 Fax +378.0549.903793  
[www.camsgroup.com](http://www.camsgroup.com) info@camsgroup.com

