

FILTRO DEPOLVERATORE

FCSI 36/12



Caratteristiche Filtro FCSI36/12

- Superficie filtrante 12 m²;
- Pulizia delle calze a contro lavaggio pneumatico;
- Calze in agugliato poliestere 500 g/m², Ø 120x830 mm con attacco SNAP;
- Velocità max consigliata di attraversamento calze 1,5 m/1';
- Consumo aria per pulizia calze 180 l/1' circa;
- Pressione massima di esercizio 5 ate;
- Quadro per gestione pulizia calze con o senza pressostato;
- Tensione alimentazione quadro elettrico 24/110/220V AC;
- Corpo filtro in Aisi 304 2B con portello di ispezione;
- Cappello in Fe360B zincato;
- Predisposizione per camino o aspiratore.

FILTRI DEPOLVERATORI



CON O SENZA
PRESSOSTATO
DIFFERENZIALE

INSTALLAZIONE SU
SILO O A TERRA SU
TRAMOGGIA

SUPERFICIE
FILTRANTE 12 M²



KIT ASPIRATORE RM 310 + MOTORE 1,5 kW
Cod.30.060.1312

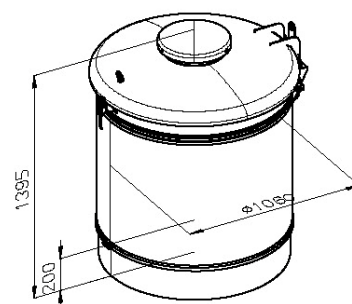
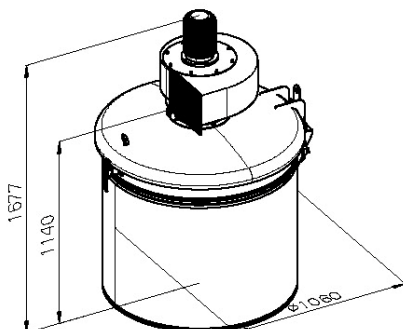
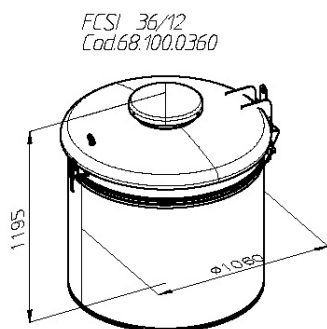

ANELLO DI RACCORDO FC 1060-B
Cod.27.0015106

CAMINO DIRITTO
Cod.30.030.0515

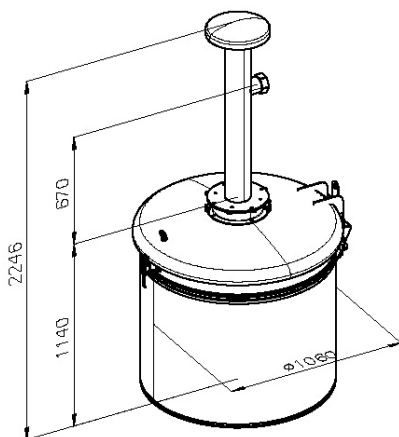

CAMINO CURVO
Cod.30.030.0500

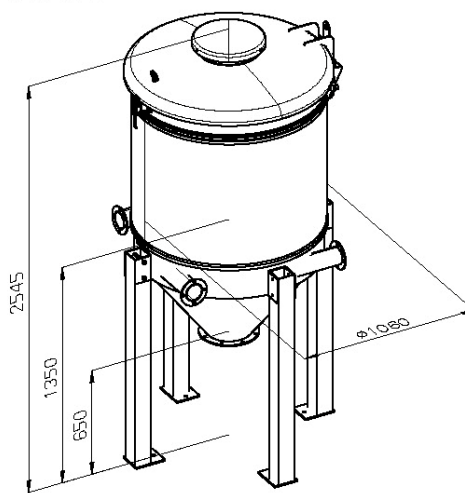
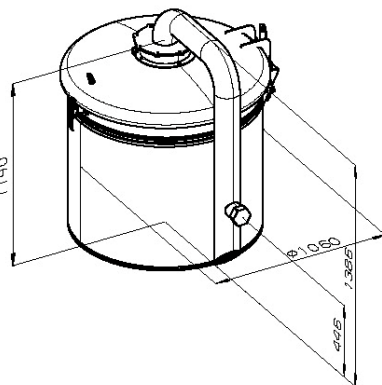

TRAMOGGIA TFC 1060-B
Cod.30.020.1107

Modello Filtro	Codice magazzino	Superficie filtrante	Diametro filtro mm	H= Filtro mm	Numero calze	Numero EV	Dimensioni imballo mm	Peso lordo kg
FCSI36/12+ quadro	68.100.0360	12 m ²	1060	1195	36	2	1100x1100x1300	130
FCSI36/12+ quadro+pressostato	68.100.0361	12 m ²	1060	1195	36	2	1100x1100x1300	130

CAMS INDUSTRIALE S.P.A.

Strada S. Michele, 37 Cailungo B5 BORGO MAGGIORE
REPUBBLICA DI SAN MARINO

Tel. +378.0549.988111 Fax +378.0549.903793

www.camsgroup.com info@camsgroup.com

