

FILTRO DEPOLVERATORE



FCSI 60/40



Caratteristiche Filtro FCSI60/40

- Superficie filtrante 40 m²;
- Pulizia delle calze a contro lavaggio pneumatico;
- Calze in agugliato poliestere 500 g/m² , Ø 120x1750 mm con attacco SNAP;
- Velocità max consigliata di attraversamento calze 1,5 m/1';
- Consumo aria per pulizia calze 180 l/1' circa;
- Pressione massima di esercizio 5 ate;
- Quadro per gestione pulizia calze con o senza pressostato;
- Tensione alimentazione quadro elettrico 24/110/220V AC;
- Corpo filtro in Aisi 304 2B con portello di ispezione;
- Cappello in Fe360B zincato;
- Predisposizione per camino o aspiratore

FILTRI DEPOLVERATORI



CON O SENZA
PRESSOSTATO
DIFFERENZIALE

INSTALLAZIONE SU
SILO O A TERRA SU
TRAMOGGIA

SUPERFICIE
FILTRANTE 40 M²

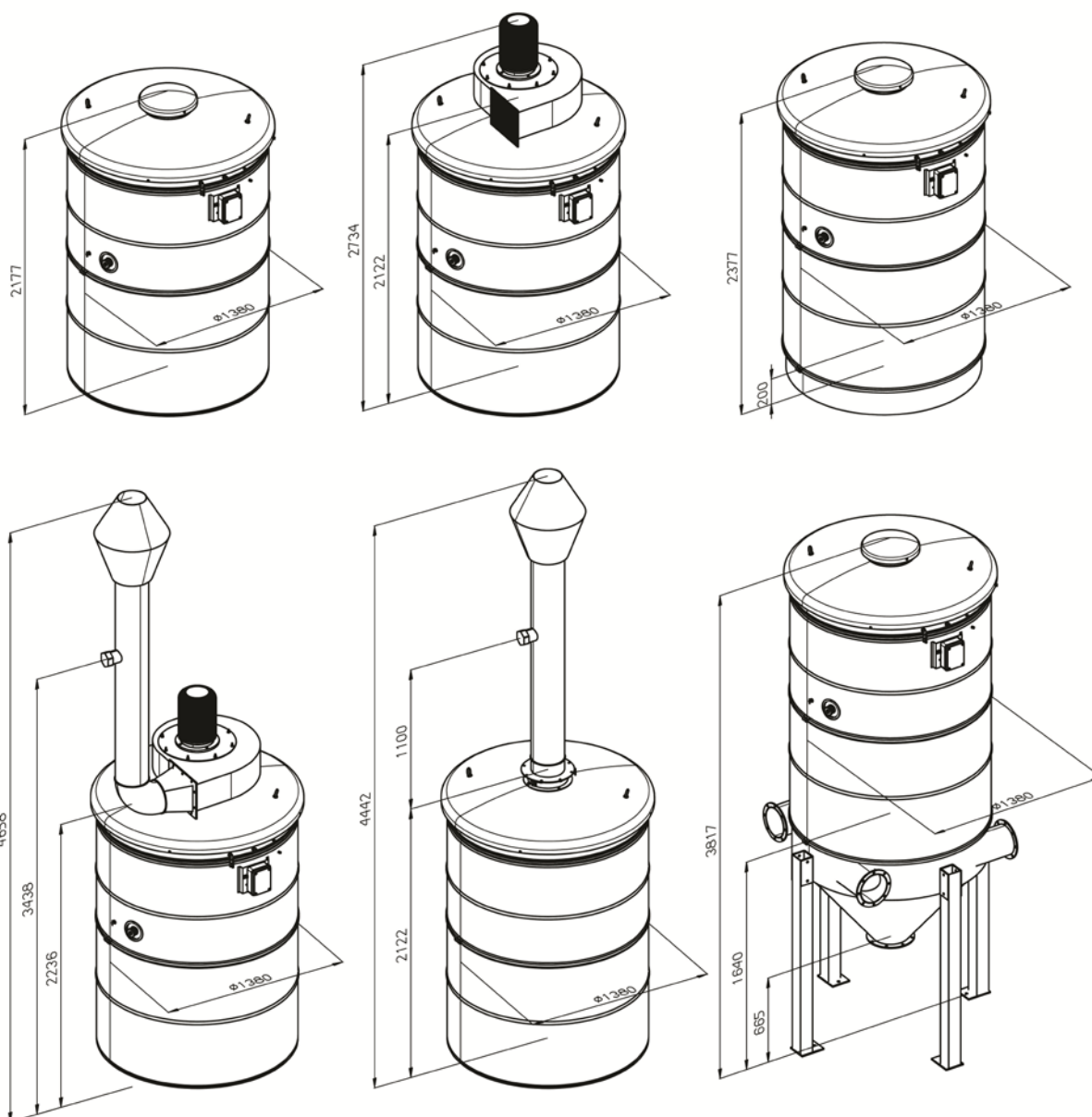

Modello Filtro	Codice magazzino	Superficie filtrante	Diametro filtro mm	H= Filtro mm	Numero calze	Numero EV	Dimensioni imballo mm	Peso lordo kg
FCSI60/40+ quadro	68.100.0600	40 m ²	1380	2100	60	6	1500x1500x2300	200
FCSI60/40+ quadro+pressostato	68.100.0601	40 m ²	1380	2100	60	6	1500x1500x2300	200

CAMS INDUSTRIALE S.P.A.
Strada S. Michele, 37 Cailungo B5 BORGO MAGGIORE
REPUBBLICA DI SAN MARINO
Tel. +378.0549.988111 Fax +378.0549.903793
www.camsgroup.com info@camsgroup.com

