

MINIESCAVATORE

Mod. 224S



MINIESCAVATORE



MINIESCAVATORE

Mod. 224S



PESO OPERATIVO
Kg. 2.500

PROFONDITA' DI SCAVO
mm 2.550

POTENZA MOTORE
HP 26,8 Kw 21

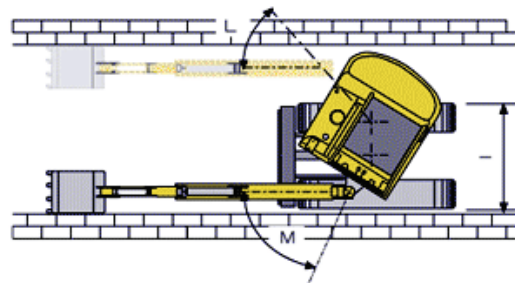
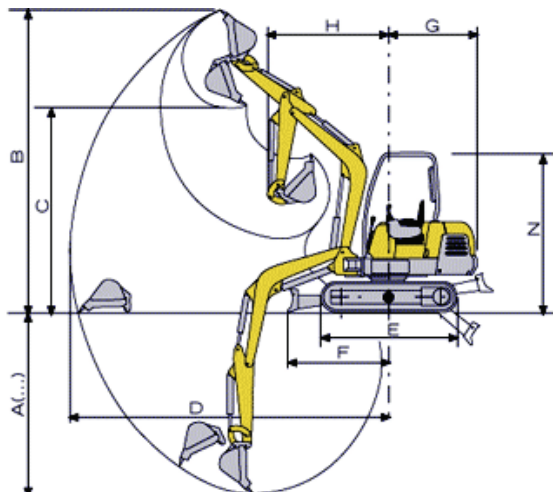

(...) misure inerenti alla configurazione con braccio lungo

measurements regarding long arm configuration

A	B	C	D	E	F	G	H	I	L	M	N
2550 (2700)	4360	3000	4529	1830	1460	1220	1750	1470	55°	80°	2345

CARATTERISTICHE TECNICHE

Peso con tettuccio/cabina	kg	2450/2520
Forza di rottura alla benna	kg	2100
Altezza alla cabina	mm	2345
Larghezza carro	mm	1470
Profondità di scavo	mm	2550(2700)
Altezza max con benna e braccio alzati	mm	4360
Pendenza superabile		38°-80%
Pressione al suolo	kg/cm ²	0,27
Velocità di trasferimento	Km/h	2,5-4,5
Velocità di rotazione	giri/min	10
Motore Kubota	Cil-cm ³	3-1499
Potenza massima	Kw -giri/min	21 - 2100
Pompe idrauliche	lt/min	2x27,3 port.var 2x16,8 fissa
Pressione esercizio	bar	220-220-200
Gruppo traslazione-rotazione		a pistoni assiali
Cingolatura gomma (opt acciaio)	mm	300x72x55
Serbatoio olio/gasolio	lt	43/36
Allestimento		Tettuccio cabina

CAMS MACCHINE S.P.A.

Strada S. Michele, 37 Cailungo B5 BORGO MAGGIORE R.S.M.

Tel. +378.0549.988111 Fax +378.0549.903793

www.camsgroup.com info@camsgroup.com

