

# MINIPALA GOMMATA

## Mod. 985



MINIPALA GOMMATA



# MINIPALA COMPATTA

## Mod. 985

**PESO  
OPERATIVO**  
Kg. 3.150

**CARICO  
OPERATIVO**  
Kg.908

**POTENZA  
MOTORE**  
Kw 55,4

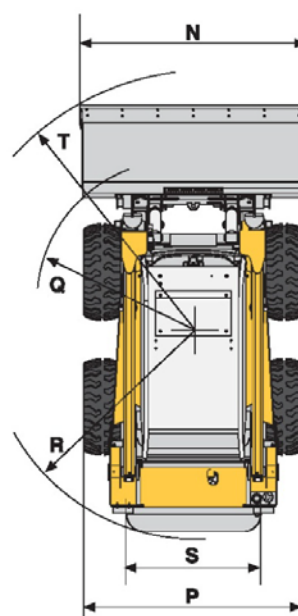
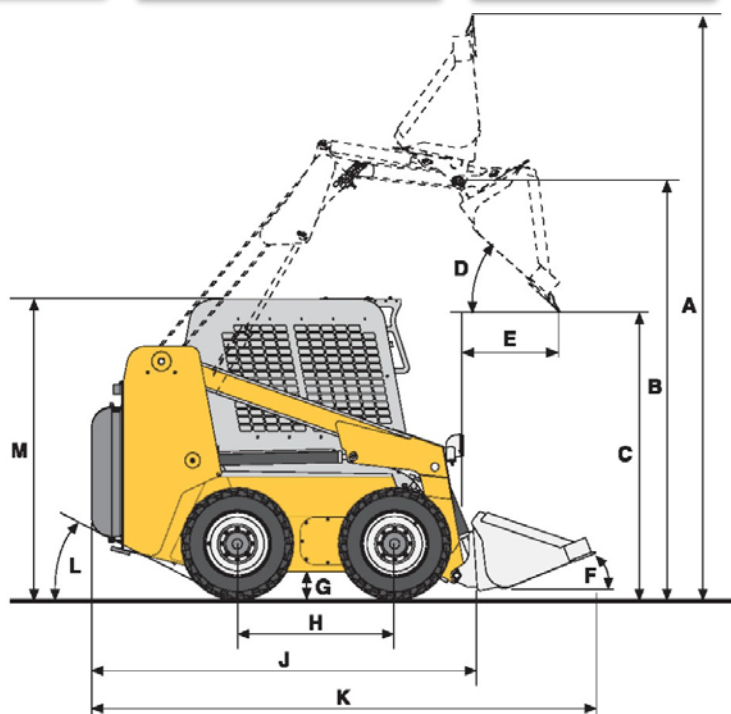

DIMENSIONI		
A – Altezza massima operativa	mm	4.023
B – Altezza perno benna	mm	3.044
C – Altezza di scarico	mm	3.073
D – Angolo di scarico	°	38
E – Distanza di scarico ad alt. Max	mm	650
F – Angolo chiusura benna	°	28
G – Altezza minima da suolo	mm	201
H – Interasse	mm	1.067
J – Lunghezza tot. senza benna	mm	2.769
K – Lunghezza tot. con benna stand.	mm	3.500
L – Angolo di partenza post.	°	24
M – Altezza max veicolo	mm	2.045
N – Larghezza max con benna stand.	mm	1.879
P – Larghezza max senza benna	mm	1.829
Q – Diametro ingombro ant.	mm	1.279
R – Diametro ingombro post.	mm	1.626
S – Larghezza battistrada-carreggiata	mm	1.519
T – Diametro ingombro ant.	mm	2.025

CARATTERISTICHE TECNICHE			
Peso operativo	Kg	3.150	
Carico operativo	Kg	908	
Carico di ribaltamento	Kg	1.816	
Velocità	Km/h	0-10 0-16	
Serbatoio olio / gasolio	l	55/87	
Motore	KUBOTA		
Cilindrata	cc	3.331	
Potenza / giri/min	Kw	55,4/ 2500	
Pompe idrostatiche	bar l/min	350 2x125	
Pompa servizi	bar l/min	180 72	
Pompa H.F.	bar l/min	180 180	
Raffreddamento	Acqua/aria		
Pneumatici	12-16,5		

**CAMS MACCHINE S.P.A.**

Strada S. Michele, 37 Cailungo B5 BORGO MAGGIORE R.S.M.

Tel. +378.0549.988111 Fax +378.0549.903793

[www.camsgroup.com](http://www.camsgroup.com) info@camsgroup.com

