

MINIPALA CINGOLATA

Mod. T865



MINIPALA CINGOLATA



MINIPALA CINGOLATA

Mod. T865

PESO OPERATIVO
Kg. 3.400

CARICO OPERATIVO
Kg.1030

POTENZA MOTORE
Kw 47,5

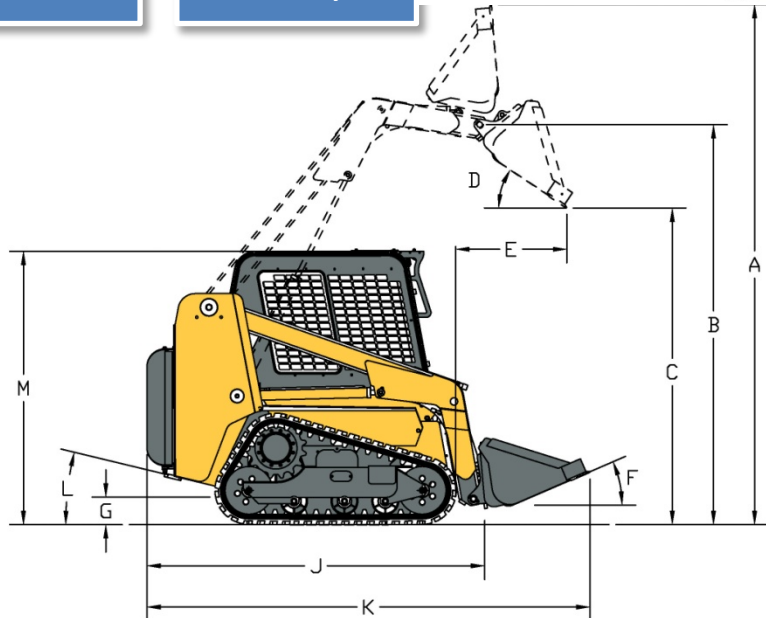
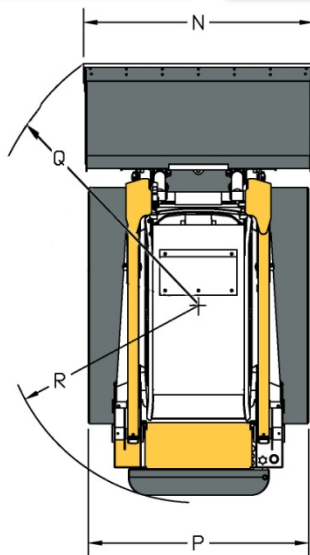

DIMENSIONI		
A – Altezza massima operativa	mm	3.767
B – Altezza perno benna	mm	2.891
C – Altezza di scarico	mm	2.281
D – Angolo di scarico	°	36
E – Distanza di scarico ad alt. Max	mm	610
F – Angolo chiusura benna	°	29
G – Altezza minima da suolo	mm	193
H – Interasse	mm	1.275
J – Lunghezza tot. senza benna	mm	2.547
K - Lunghezza tot. con benna stand.	mm	3.239
L – Angolo di partenza post.	°	25,2
M – Altezza max veicolo	mm	1.978
N – Larghezza max con benna stand.	mm	1.727
P - Larghezza max senza benna	mm	1.651
Q –Diametro ingombro ant.	mm	1.161
R - Diametro ingombro post.	mm	1.487
S –Larghezza battistrada-carreggiata	mm	1.245
T –Diametro ingombro ant.	mm	1.956

CARATTERISTICHE TECNICHE		
Peso operativo	Kg	3.400
Carico operativo 50%	Kg	1030
Carico operativo 35%	Kg	721
Carico di ribaltamento	Kg	2.060
Velocità	Km/h	0-7,5/11,5
Serbatoio olio / gasolio	l	38/66
Motore		KUBOTA
Cilindrata	cc	2.615 turbo
Potenza / giri/min	Kw	47,5 / 2500
Pompe idrostatiche	bar l/min	345 2x113
Pompa servizi	bar l/min	180 70
Raffreddamento		Acqua/aria
Cingoli		320x86x48

CAMS MACCHINE S.P.A.

Strada S. Michele, 37 Cailungo B5 BORGO MAGGIORE R.S.M.

Tel. +378.0549.988111 Fax +378.0549.903793

www.camsgroup.com info@camsgroup.com

