

# SKID LOADER 865



SKID LOADERS



# SKID LOADER

## Mod. 865

**WEIGHT**  
Kg. 2.750

**OPERATING WEIGHT**  
Kg.680

**ENGINE POWER**  
Kw 47,5

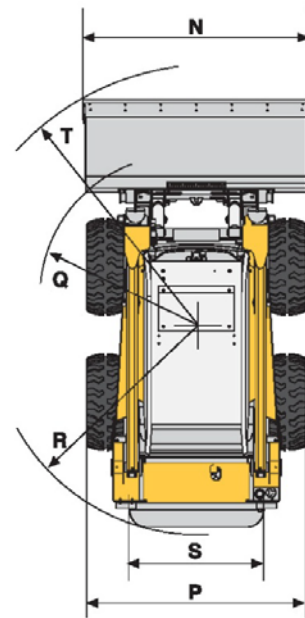
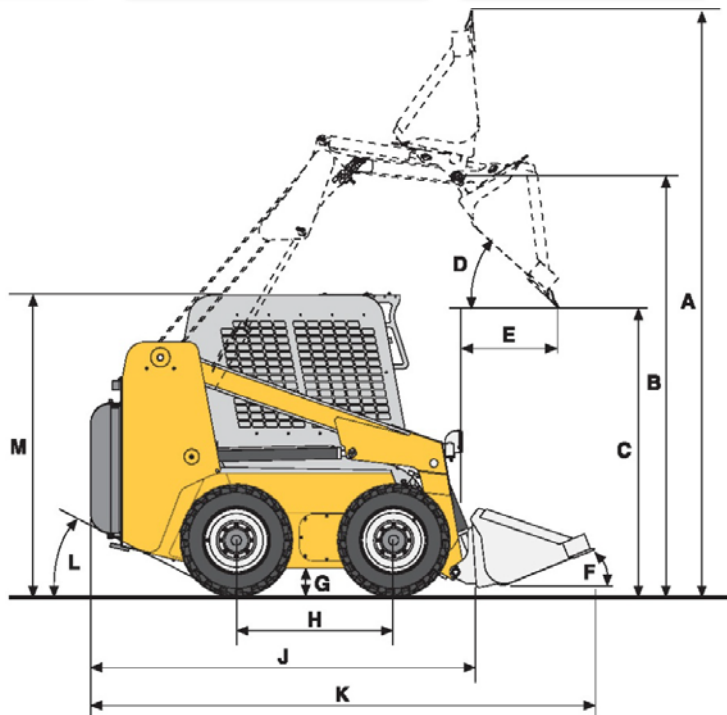

DIMENSIONS		
A – Maximum operating height	mm	3.767
B – Bucket pin height	mm	2.891
C – Dump height	mm	2.281
D – Dump angle	°	36
E – Dump clearance at max height	mm	610
F – Bucket closure angle	°	29
G – Minimum height from ground	mm	193
H – Wheelbase	mm	1.016
J – Total length without bucket	mm	2.547
K – Total length with standard bucket	mm	3.239
L – Rear starting angle	°	25,2
M – Maximum machine height	mm	1.981
N – Max. width with standard bucket	mm	1.727
P – Max width without standard bucket	mm	1.651
Q – Front diameter	mm	1.161
R – Rear diameter	mm	1.487
S – Track tread width	mm	1.245
T – Front diameter	mm	1.956

Technical specifications			
Operating weight	Kg	2.750	
Operating capacity	Kg	680	
Tipping load	Kg	1.360	
Speed	Km/h	0-11,5	
Fuel tank capacity oil/diesel	l	38/66	
Engine		KUBOTA	
Displacement	cc	2.615 turbo	
Net power / rpm	Kw	47,5 / 2500	
Hydrostatic drive pumps	bar l/min	345 2x113	
Gear pump	bar l/min	180 70	
Cooling system		Heat exchanger	
Tires		10-16,5	

**CAMS MACCHINE S.P.A.**  
Strada S. Michele, 37 Cailungo B5 BORGO MAGGIORE R.S.M.  
Tel. +378.0549.988111 Fax +378.0549.903793  
[www.camsgroup.com](http://www.camsgroup.com) info@camsgroup.com

