

SKID LOADER

Mod. 985



SKID LOADERS



SKID LOADER

Mod. 985

WEIGHT

Kg. 3.150

OPERATING WEIGHT

Kg.908

ENGINE POWER

Kw 55,4

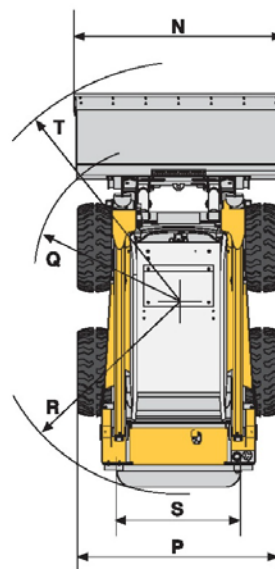
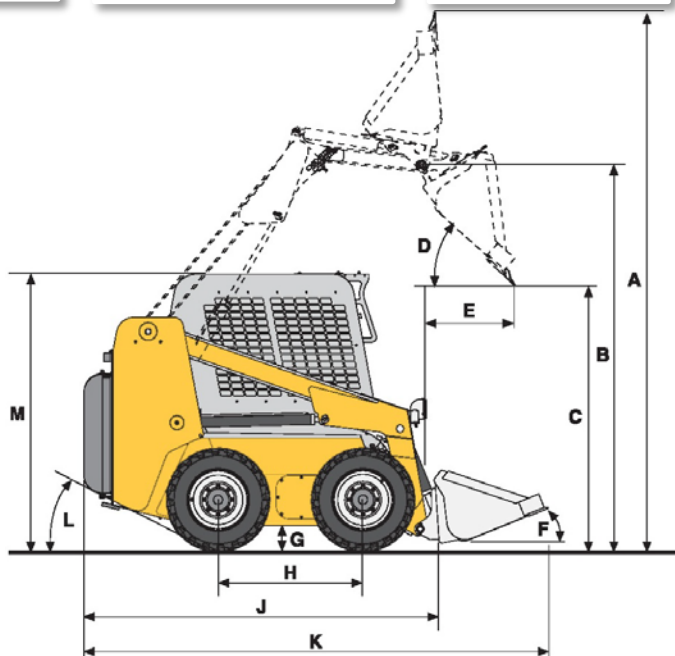

DIMENSIONI

A – Maximum operating height	mm	4.023
B – Bucket pin height	mm	3.044
C – Dump height	mm	3.073
D – Dump angle	°	38
E – Dump clearance at max height	mm	650
F – Bucket closure angle	°	28
G – Minimum height from ground	mm	201
H – Wheelbase	mm	1.067
J – Total length without bucket	mm	2.769
K – Total length with standard bucket	mm	3.500
L – Rear starting angle	°	24
M – Maximum machine height	mm	2.045
N – Max. width with standard bucket	mm	1.879
P – Max width without standard bucket	mm	1.829
Q – Front diameter	mm	1.279
R – Rear diameter	mm	1.626
S – Track tread width	mm	1.519
T – Front diameter	mm	2.025

CARATTERISTICHE TECNICHE

Operating weight	Kg	3.150
Operating capacity	Kg	908
Tipping load	Kg	1.816
Speed	Km/h	0-10 0-16
Fuel tank capacity oil/diesel	l	55/87
Engine		KUBOTA
Displacement	cc	3.331
Net power / rpm	Kw	55,4/ 2500
Hydrostatic drive pumps	bar l/min	350 2x125
Gear pump	bar l/min	180 72
Gear H.F.	bar l/min	180 180
Cooling system		Heat exchanger
Tires		12-16,5

CAMS MACCHINE S.P.A.

Strada S. Michele, 37 Cailungo B5 BORGO MAGGIORE R.S.M.

Tel. +378.0549.988111 Fax +378.0549.903793

www.camsgroup.com info@camsgroup.com

