

# MINIESCAVATORE

## Mod. 216 STAGE V



MINIESCAVATORE



# MINIESCAVATORE

## Mod. 216 STAGE V

**PESO OPERATIVO**

**Kg.  
1.550/1650**

**PROFONDITA' DI SCAVO**

**mm 2.150**

**POTENZA MOTORE**

**HP 17 Kw 12,5**

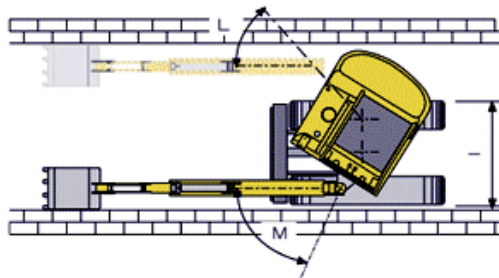
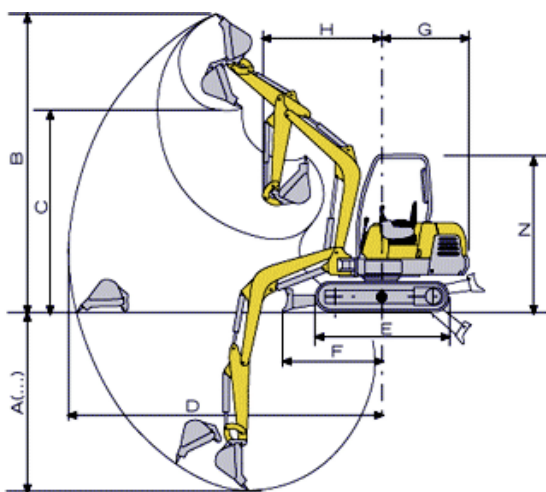

(...) misure inerenti alla configurazione con braccio lungo

measurements regarding long arm configuration

A	B	C	D	E	F	G	H	I	L	M	N
2150(2350)	3360	2300	3730	1485	1120	1045	1530	1000	50°	85°	2250

### CARATTERISTICHE TECNICHE

<b>Peso con tettuccio/cabina</b>	kg	1550/1650
<b>Forza di rottura alla benna</b>	kg	1500
<b>Altezza alla cabina</b>	mm	2250
<b>Larghezza carro</b>	mm	1000
<b>Profondità di scavo</b>	mm	2150(2350)
<b>Altezza max con benna e braccio alzati</b>	mm	3360
<b>Pendenza superabile</b>		35° - 70%
<b>Pressione al suolo</b>	kg/cm <sup>2</sup>	0,27
<b>Velocità di trasferimento</b>	Km/h	2-3,8
<b>Velocità di rotazione</b>	giri/min	11,5
<b>Motore Kubota D902-E4B STAGE V</b>	Cil-cm <sup>3</sup>	3-898
<b>Potenza massima</b>	Kw -giri/min	12,5 - 2200
<b>Pompe idrauliche</b>	lt/min	2x17,6 port.var 1x17,6+1x13,2 fissa
<b>Pressione esercizio</b>	bar	210-210-180
<b>Gruppo traslazione-rotazione</b>		a pistoni assiali
<b>Cingolatura gomma (opt acciaio)</b>	mm	230x35x96
<b>Serbatoio olio/gasolio</b>	lt	18/22
<b>Allestimento</b>		Tettuccio / cabina

CAMS MACCHINE S.P.A.

Strada S. Michele, 37 Cailungo B5 BORGO MAGGIORE R.S.M.

Tel. +378.0549.988111 Fax +378.0549.903793

[www.camsgroup.com](http://www.camsgroup.com) info@camsgroup.com



**CAMS  
MACCHINE**

