

MINIESCAVATORE

Mod. 218sv STAGE V



MINIESCAVATORE



MINIESCAVATORE

Mod. 218 sv STAGE V

**PESO
OPERATIVO**

**Kg
1585/1800**

**PROFONDITA' DI
SCAVO**

mm 2.350

**POTENZA
MOTORE**

HP 17 Kw12,5

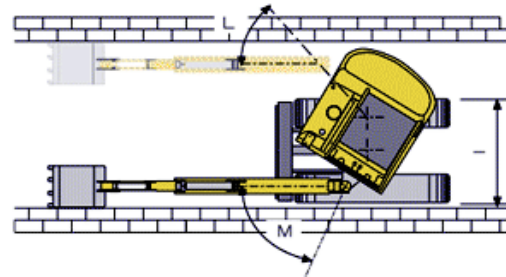
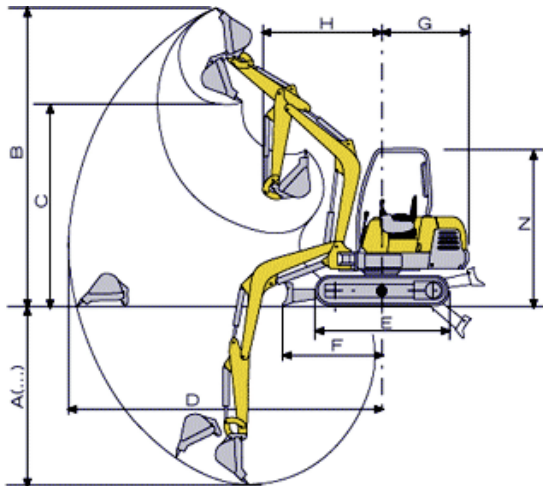

(...) misure inerenti alla configurazione con braccio lungo

measurements regarding long arm configuration

A	B	C	D	E	F	G	H	I	L	M	N
2350	3470	2400	3920	1485	1120	1045	1530	min.1000 max. 1300	50°	85°	2250

CARATTERISTICHE TECNICHE

Peso con tettuccio/cabina	kg	1585/1800
Forza di rottura alla benna	kg	1500
Altezza alla cabina	mm	2250
Larghezza carro variabile	mm	Min/Max 1000/1300
Profondità di scavo	mm	2350
Altezza max con benna e braccio alzati	mm	3470
Pendenza superabile		35° - 70%
Pressione al suolo	kg/cm ²	0,27
Velocità di trasferimento	Km/h	2-3,8
Velocità di rotazione	giri/min	11,5
Motore Kubota D902-E4B STAGE V	Cil-cm ³	3-898
Potenza massima	Kw -giri/min	12,5 - 2200
Pompe idrauliche	lt/min	2x17,6 port.var 1x17,6+1x13,2 fissa
Pressione esercizio	bar	210-210-180
Gruppo traslazione-rotazione		a pistoni assiali
Cingolatura gomma (opt acciaio)	mm	230x35x96
Serbatoio olio/gasolio	lt	18/22
Allestimento		Tettuccio / cabina

CAMS MACCHINE S.P.A.

Strada S. Michele, 37 Cailungo B5 BORGO MAGGIORE R.S.M.

Tel. +378.0549.988111 Fax +378.0549.903793

www.camsgroup.com info@camsgroup.com



**CAMS
MACCHINE**

