

# MINIESCAVATORE

## Mod. CZ55 STAGE V



MINIESCAVATORE



# MINIESCAVATORE

## Mod. CZ55 STAGE V

**PESO  
OPERATIVO**

**Kg.  
5.400/5.500**

**PROFONDITA' DI  
SCAVO**

**mm 3.450**

**POTENZA  
MOTORE**

**Kw 31,3**

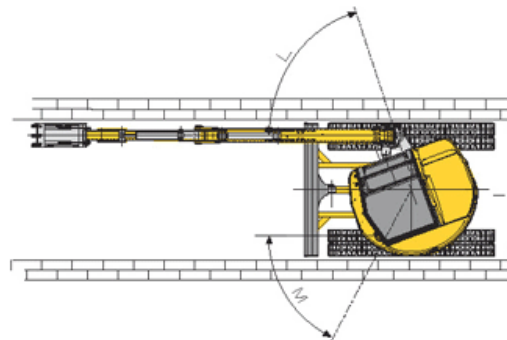
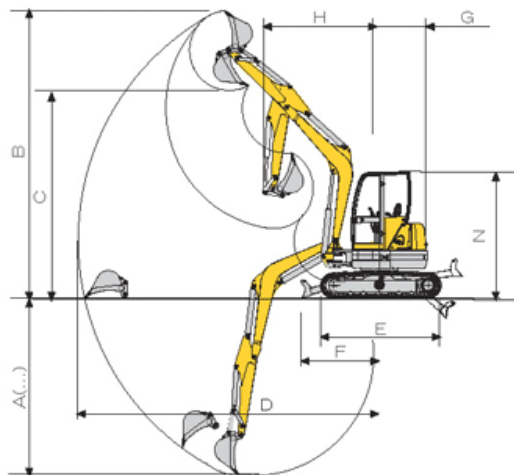

(...) misure inerenti alla configurazione con braccio lungo  
measurements regarding long arm configuration

A	B	C	D	E	F	G	H	I	L	M	N
3450	6160	4550	6060	2460	1560	1080	2460	1960	70°	60°	2560

### CARATTERISTICHE TECNICHE

<b>Peso con tettuccio/cabina</b>	kg	5400/5500
<b>Forza di rottura alla benna</b>	kg	3850
<b>Altezza alla cabina</b>	mm	2560
<b>Larghezza carro</b>	mm	1960
<b>Profondità di scavo</b>	mm	3450
<b>Altezza max con benna e braccio alzati</b>	mm	6160
<b>Pendenza superabile</b>		30° - 58%
<b>Pressione al suolo</b>	kg/cm <sup>2</sup>	0,36
<b>Velocità di trasferimento</b>	Km/h	2,8-5
<b>Velocità di rotazione</b>	giri/min	10
<b>Motore DOOSAN STAGE V TURBO</b>	Cil-cm <sup>3</sup>	3-1794
<b>Potenza massima</b>	Kw -giri/min	31,3 - 2200
<b>Pompe idrauliche</b>	lt/min	2x55,2 port.var 1x41,8 + 1x16,5 fisse
<b>Pressione esercizio</b>	bar	250-250-210
<b>Gruppo traslazione-rotazione</b>		a pistoni assiali
<b>Cingolatura gomma (opt acciaio)</b>	mm	400x72x72,5
<b>Serbatoio olio/gasolio</b>	lt	48/53,5
<b>Allestimento</b>		Tettuccio cabina

CAMS MACCHINE S.P.A.

Strada S. Michele, 37 Cailungo B5 BORGO MAGGIORE R.S.M.

Tel. +378.0549.988111 Fax +378.0549.903793

[www.camsgroup.com](http://www.camsgroup.com) info@camsgroup.com



**CAMS  
MACCHINE**

